

**UNIVERSITY COLLEGE TATI (UC TATI)****FINAL EXAMINATION QUESTION BOOKLET**

COURSE CODE	: DEI 2053
COURSE	: PROGRAMMABLE LOGIC CONTROLLER
SEMESTER/SESSION	: 2-2022/2023
DURATION	: 3 HOURS

**Instructions:**

1. This booklet contains **4** questions. Answer **ALL** questions.
2. All answers should be written in answer booklet.
3. Write legibly and illustrate sketches wherever required.
4. If in doubt, raise up your hands and ask the invigilator.

**DO NOT OPEN THIS BOOKLET UNTIL YOU ARE TOLD TO DO SO**

**THIS BOOKLET CONTAINS 5 PRINTED PAGES INCLUDING COVER PAGE**

**QUESTION 1**

- a. Give the definition of Programmable Logic Controller (PLC). (3 marks)
- b. State three (3) advantages of Programmable Logic Controller (PLC). (3 marks)
- c. List four (4) PLC input or output components that usually used in the lab. (4 marks)
- d. Draw the symbols for:
  - i. Roller limit switch (1 mark)
  - ii. Relay box (1 mark)
  - iii. Solenoid valve (1 mark)
- e. Figure 1 shows the digital logic diagram.
  - i. State the Boolean equation for digital logic. (4 marks)
  - ii. Produce the Ladder Diagram Rung (LDR) from the given gate logic. (8 marks)

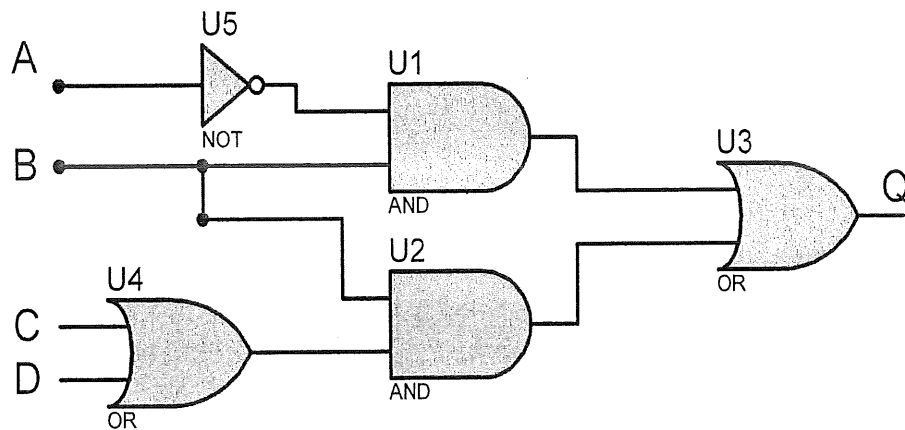

**Figure 1**

**QUESTION 2**

- a. List **four (4)** PLC programming languages. (4 Marks)
- b. State three **(3)** steps in PLC operation. (3 marks)
- c. For the following Boolean equation, produce the ladder logic rung. (6 Marks)

$$X = (ABC + D) * E$$

- d. From Figure 2:
- i. State the Boolean equation for the output. (4 Marks)
- ii. Produce the ladder diagram rung (LDR) from the equation in question d (i). (8 Marks)

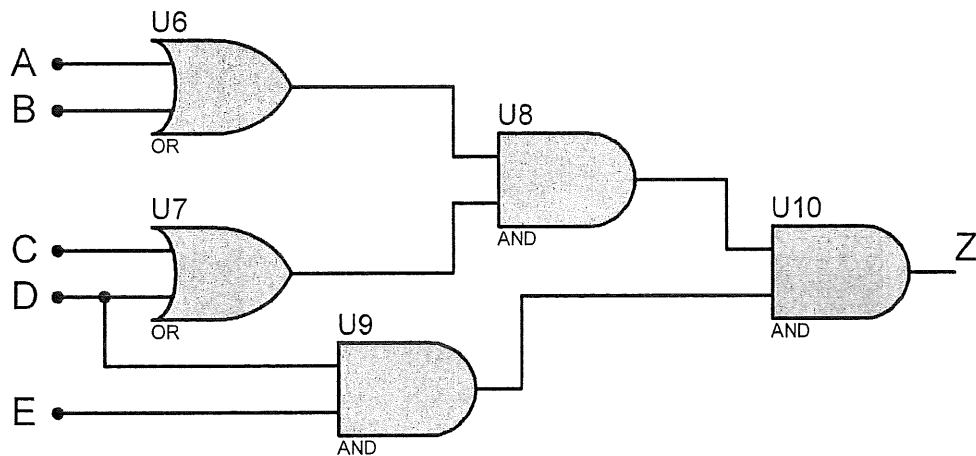
**Figure 2**

**QUESTION 3**

- a. State **four (4)** differences between Programmable Logic Controller and computers. (4 marks)
- b. By using 3/2-way single solenoid valve with spring return and single acting cylinder, the condition for the cylinder to extend and retract is as description given below: -
- By pressing Pushbutton 1 and Pushbutton 2, the cylinder will be extended.
  - Only after the cylinder is fully extended and Pushbutton 3 is pressed, the cylinder will be retracted.

By referring to the above condition,

- i. Illustrate the pneumatic circuit diagram. (3 marks)
- ii. Illustrate the PLC input/output wiring (direct wiring). (3 marks)
- iii. Produce a Ladder Diagram for the sequence above. (**using SET/RSET only**) (5 marks)
- c. Figure 3 shows a ladder diagram for a condition that should be working as below when: -

- Press PB1, lamp 1 will be on and maintain on after PB 1 is released.
- Press PB2, lamp 1 will be off.
- Press PB3 and PB4, lamp 2 will be on. If pushbuttons is released, lamp 2 will be off.

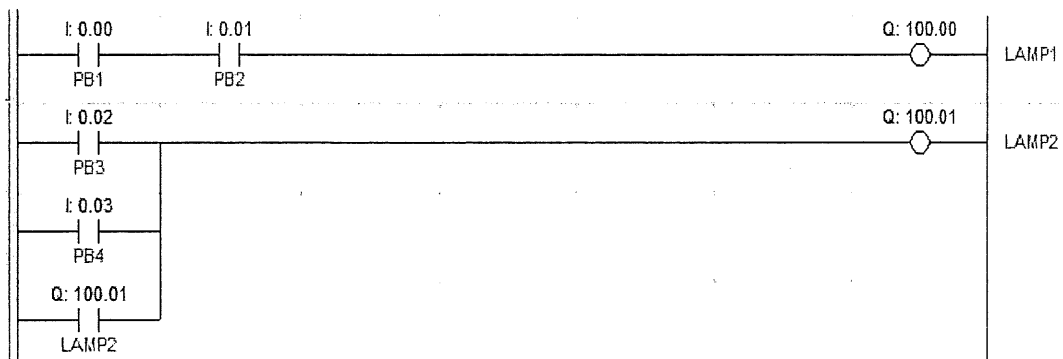

**Figure 3**

The problem is L1 and L2 is not turning ON and OFF as the condition given above. Troubleshoot and redraw / rewrite the ladder diagram above according to the given condition.

(10 marks)

**QUESTION 4**

a. The condition for the cylinder to extend and retract is as description given below: -

- Cylinder A is to be extending after Pushbutton 1 and Pushbutton 2 is pressed.
- Only after cylinder A is fully extended then, cylinder B will be extending.
- After cylinder B fully extended, confirm by limit switch, both cylinder A and B will retract at the same time.

**\*(use double solenoid valve and double acting cylinder)**

By referring to the above condition,

- Draw the pneumatic circuit with proper labeling. (6 marks)
- Illustrate the PLC input/output and electrical wiring for the system. (6 marks)
- Illustrate the electrical wiring diagram for the system. (3 marks)
- Produce the ladder diagram rung. (Use coil) (10 marks)

-----End of question -----

